

# Dazcat 10R - specification sheet



## DESIGNER

Builder  
Hull configuration  
Steering system  
Sail plan  
Helm locations  
Deck layout  
Auxiliary engine  
Engine location  
Classification  
RCD category  
Fuel  
Fresh water  
Payload

## Darren Newton

Multimarine Composites Ltd  
Open deck catamaran  
Retractable rudders with tiller steering  
Fully battened main self tacker and screecher  
Hull cockpits  
All lines lead to cockpit  
9.9hp outboard  
Beam or transom  
Racer  
Category B  
Petrol  
50ltrs  
1 tonne

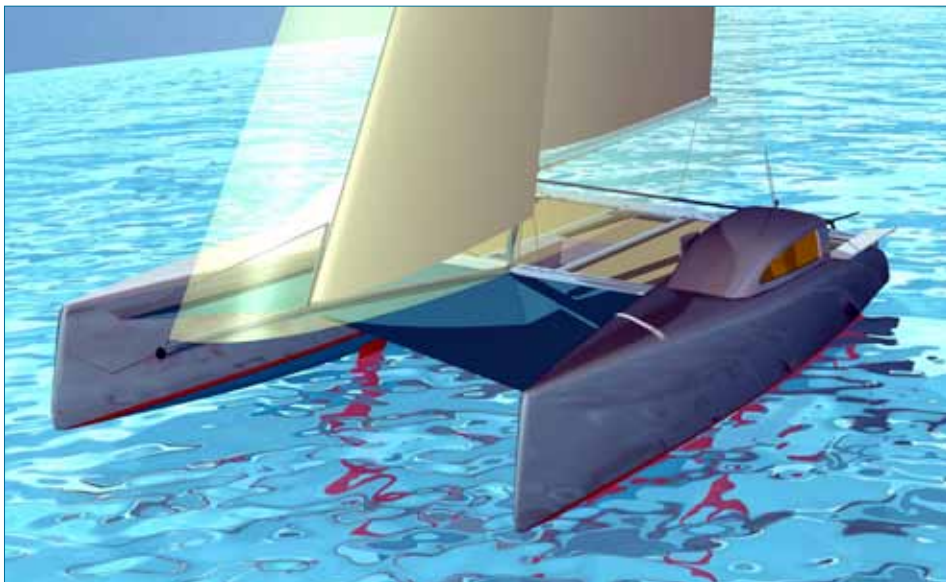

Foss Quarry  
Mill Road  
Millbrook  
Cornwall  
PL10 1EN

Tel +44 1752 823513  
Fax +44 1752 823179

info@multimarine.co.uk  
www.multimarine.co.uk

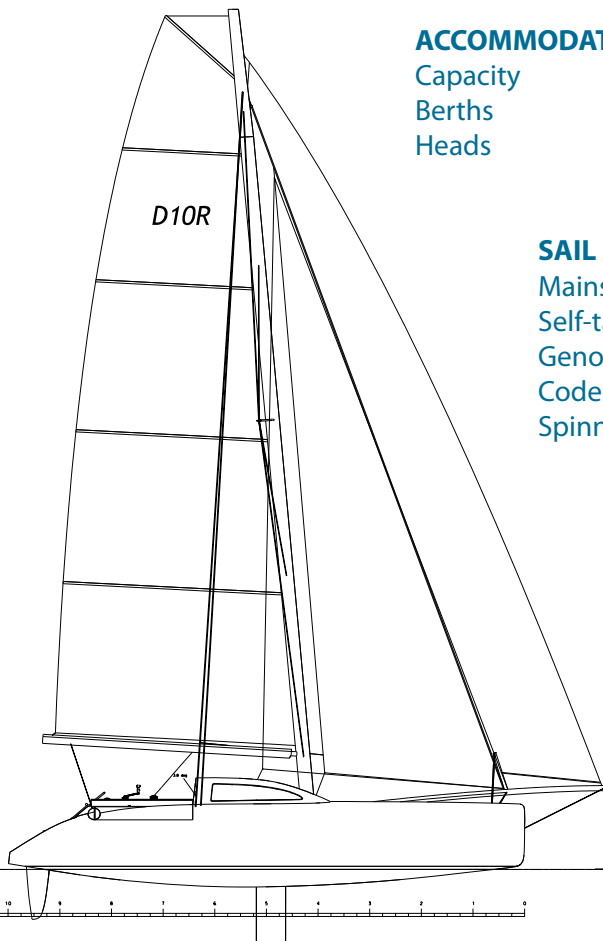

### ACCOMMODATION

Capacity	5
Berths	2 doubles, 1 single
Heads	1

### SAIL AREAS

Mainsail	45m <sup>2</sup>
Self-tacking jib	20m <sup>2</sup>
Genoa	30m <sup>2</sup>
Code 0	60m <sup>2</sup>
Spinnaker	70m <sup>2</sup>

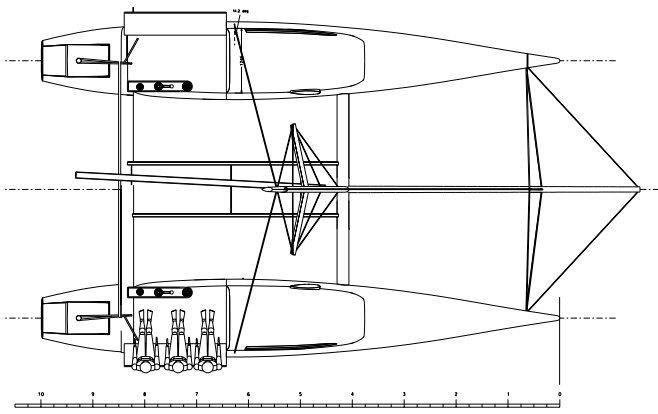
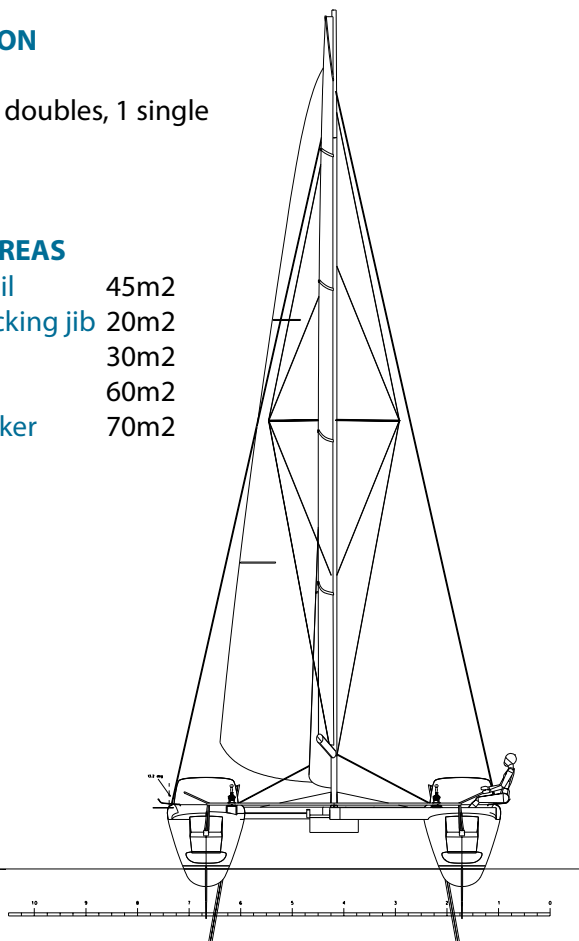

### VITAL STATISTICS

Overall length	10m
Waterline length	9.850m
Height in hulls	1.400m
Beam max	6.300m
Draft max	1.100m
Displacement lightship	1,450kg
Mast height off deck	15.500m
Mast height off water	17.000m

### OPTION A: BASIC KIT:

2 bare hulls with cockpit/coachroof mouldings and transom step mouldings supplied loose.

**Price: £24,950 + VAT** (price valid as of October 2009, subject to change)

### OPTION B: DE LUXE KIT

2 hulls , cockpit coachroofs with window and escape hatch recesses and transom steps with bulkheads and half bulkheads Bunk tops with recesses for access hatches, demountable alloy beams. The boat would at this stage float, but would need foils, hatches, windows, deck gear, and nets etc to be fitted.

**Price: £59,495 +VAT** (price valid as of October 2009, subject to change)

### OPTION C: SOME FIT OUT REQUIRED

2 hulls as above. Structurally complete, watertight, with foils, primary deck gear bolted down, windows and hatches fitted and interior painted ready to motor away for owner's installation of:

- Soft furnishings
- Plumbing
- Electrics
- Mast
- Sails
- Netting
- Blocks, jammers
- Bilge pumps, etc etc

**Price: £92,500 + VAT** (price valid as of October 2009, subject to change)

### OPTION C: COMPLETE BOAT, FULL SPEC AS ABOVE

Boat ready to sail, excluding electronic equipment,  
**£119,950 + VAT** (price valid as of October 2009, subject to change)